

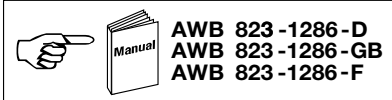

DE 4-BM2-1 DE 4-BM4-1

03/97 AWA 823-1568



AWB 823-1286-D
AWB 823-1286-GB
AWB 823-1286-F

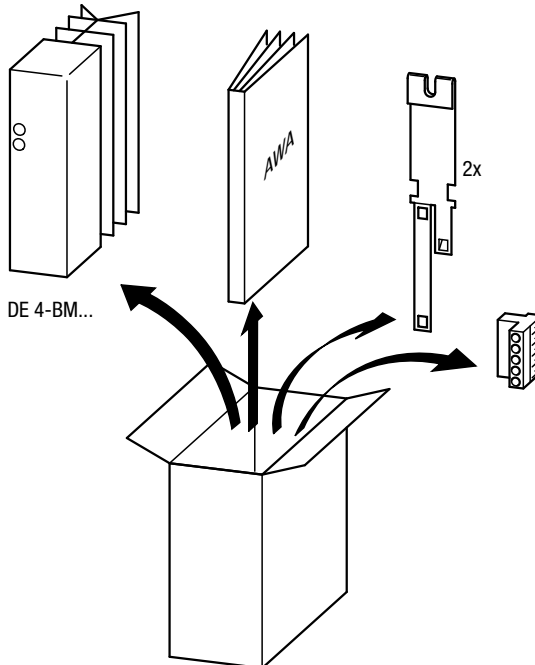
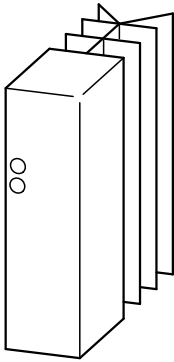

Ⓓ

Lebensgefahr durch elektrischen Strom!

Nur Elektrofachkräfte und elektrotechnisch unterwiesene Personen dürfen die im folgenden beschriebenen Arbeiten ausführen.

ⒼⒸ

Electric current! Danger to life!

Only skilled or instructed persons may carry out the following operations

Ⓕ

Tension électrique dangereuse!

Seuls les personnes qualifiées et averties doivent exécuter les travaux ci-après.

Ⓘ

Pericolo di morte causa corrente elettrica!

Solo persone istruite e avvertite possono eseguire le operazioni di seguito riportate.

Ⓔ

Corriente eléctrica! Peligro de muerte!

El trabajo a continuación descrito debe ser realizado por personas cualificadas y advertidas.

Abmessungen

Dimensions

Dimensioni

Dimensiones

Gewicht: 1,3 kg

Weight: 1,3 kg

Poids: 1,3 kg

Peso: 1,3 kg

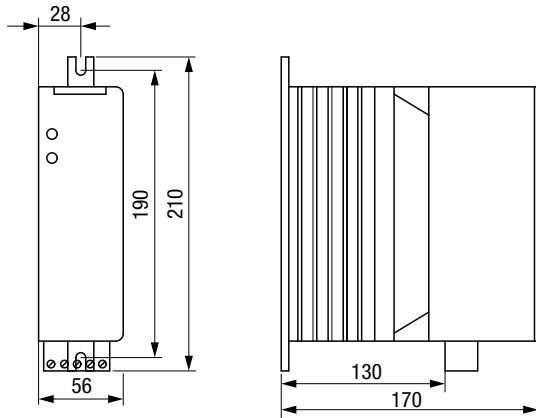

Schutzart: IP 20

Protection type: IP 20

Degré de protection: IP 20

Tipo de protezone: IP 20

Tipo de protección: IP 20

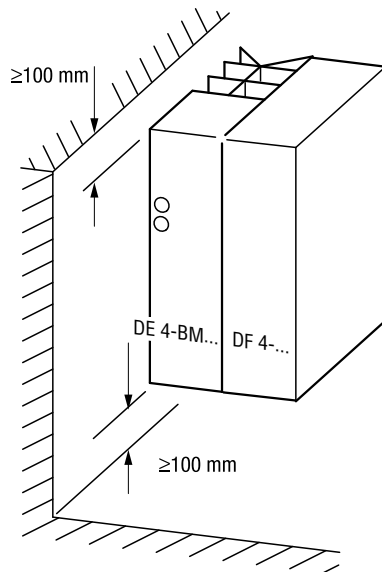
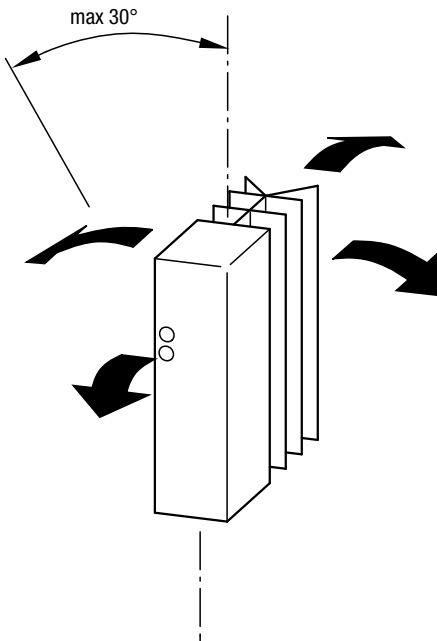

03/97 AWA 823-1568

1

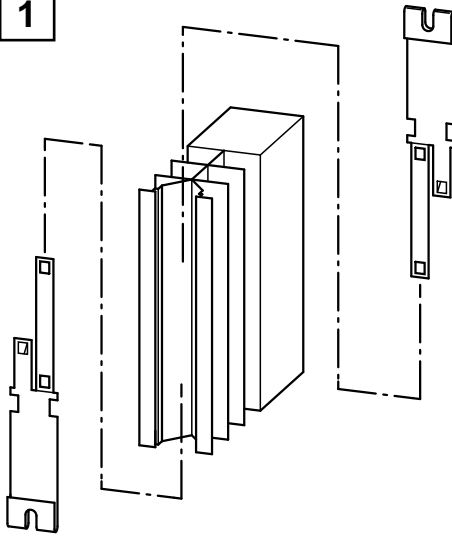

2

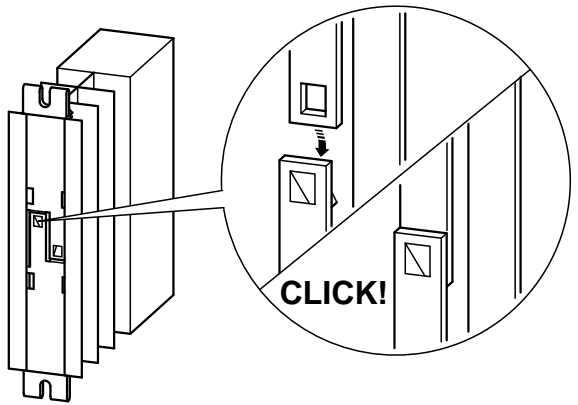

3

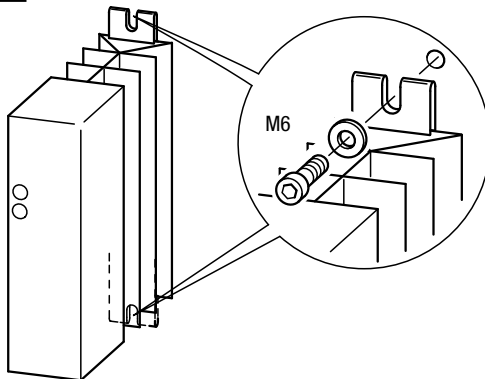

Anschlüsse
 Connections
 Raccordements
 Collegamenti
 Conexiones

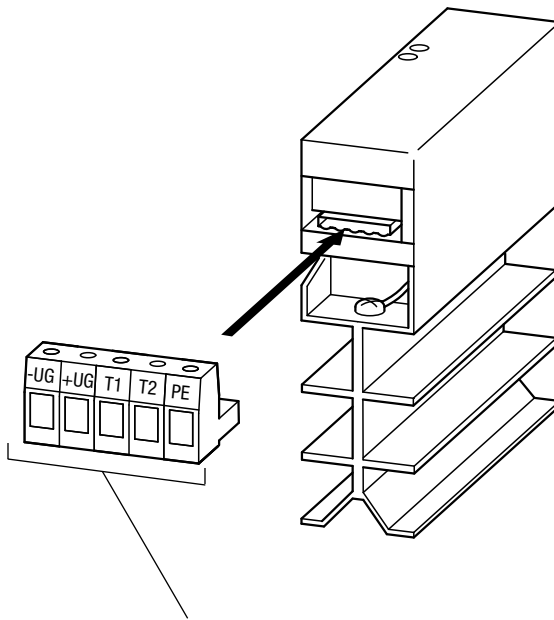

mm ²	AWG	mm	Nm	mm
1,5	14	7	0,5...0,6	0,6 x 3,5



- (D)** Im Geltungsbereich der EG-Richtlinien dürfen die Frequenzrichter der Reihe DF 4 und deren Zubehör nur dann in Betrieb genommen werden, wenn festgestellt ist, daß die Maschine die Schutzanforderungen der Maschinenrichtlinie 89/392/EEG erfüllt.
- (GB)** If the DF 4 frequency inverter is used as a component with a machine, this machine must meet the protection requirements of the 89/392/EEC Machine Directive. Otherwise commissioning of the DF 4 frequency inverters within the EEC Directive application area is prohibited.
- (F)** En cas d'utilisation du convertisseur de fréquence DF 4 et de ses accessoires, la machine répondre aux conditions de la directive Machines 89/392/CEE. Sinon la mise en service des convertisseurs DF 4 dans le champ d'application de la directive européenne est interdite.
- (I)** Il convertitore di frequenza DF 4 e i suoi accessori debbono essere impiegato soltanto se la macchina corrisponde alle norme di sicurezza contenute nella direttiva 89/392/CEE. Nel caso contrario, è vietato mettere in esercizio, sul territorio della direttiva CEE, i convertitori di frequenza DF 4.
- (E)** Se permite la puesta en servicio de los convertidores de frecuencia DF 4 y sus accesorios si se comprueba que la máquina ha de cumplir las especificaciones de protección establecidas en la Directiva 89/392/CEE sobre Máquinas.

03/97 AWA 823-1568

Schematischer Aufbau

Setup

Vue schématique

Esecuzione schematica

Esquema

03/97 AWA 823-1568

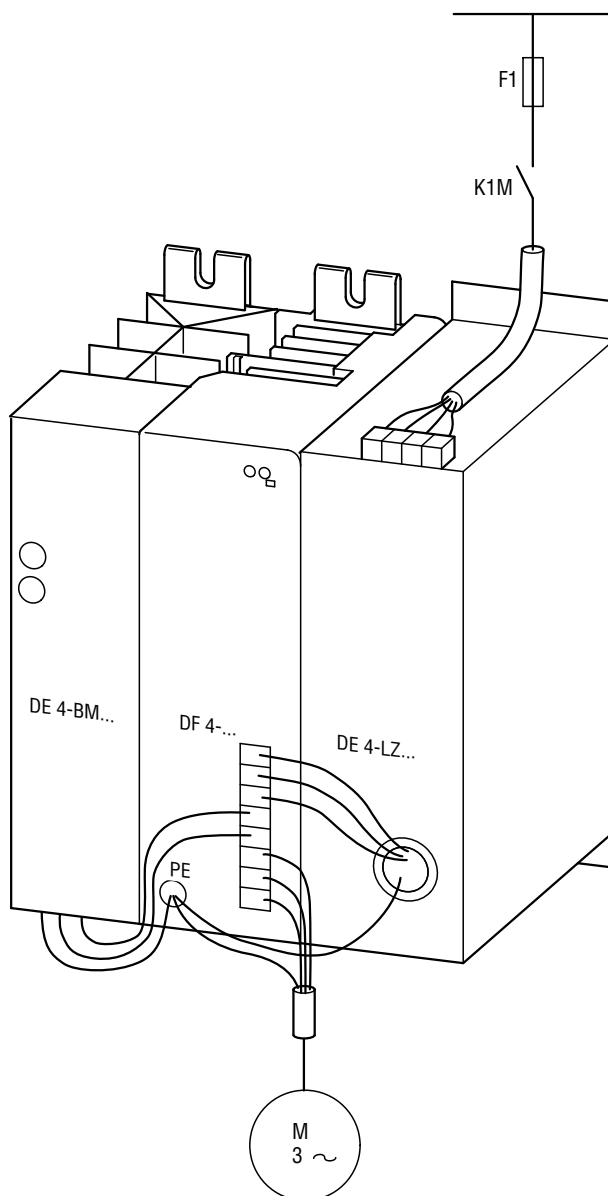

EMV-gerechter Anschluß

Connection that meets the EMC requirements

Raccordement conforme a la directive sur la CEM

Collegamento a compatibilità

Conexión que cumpla las especificaciones CEM

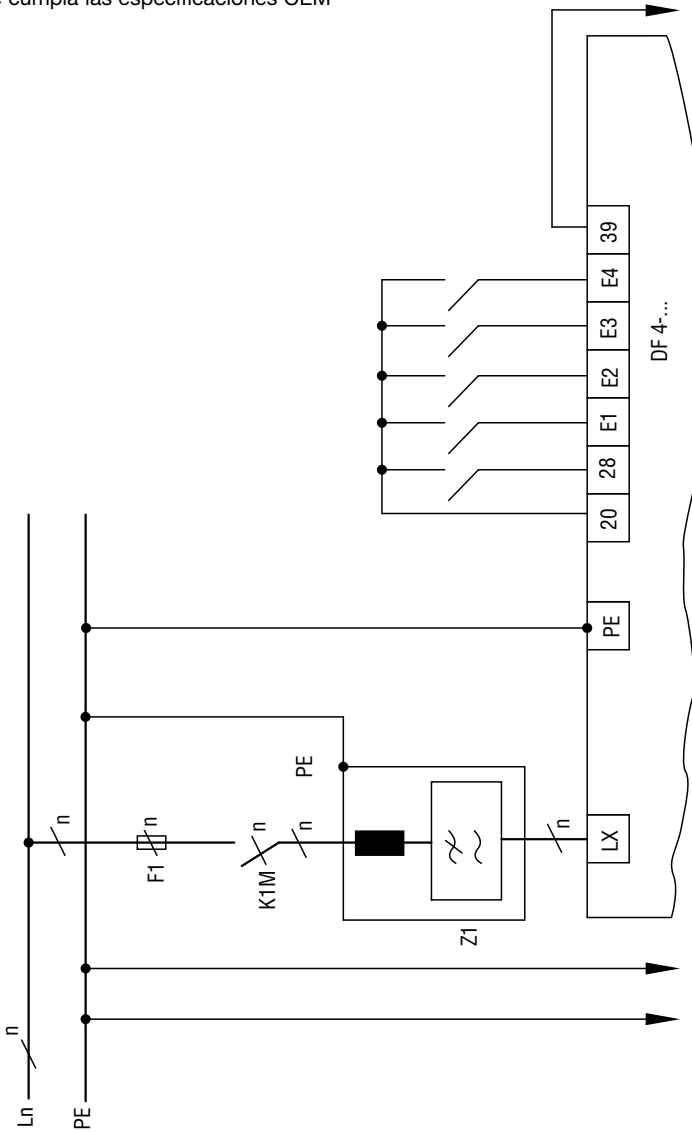

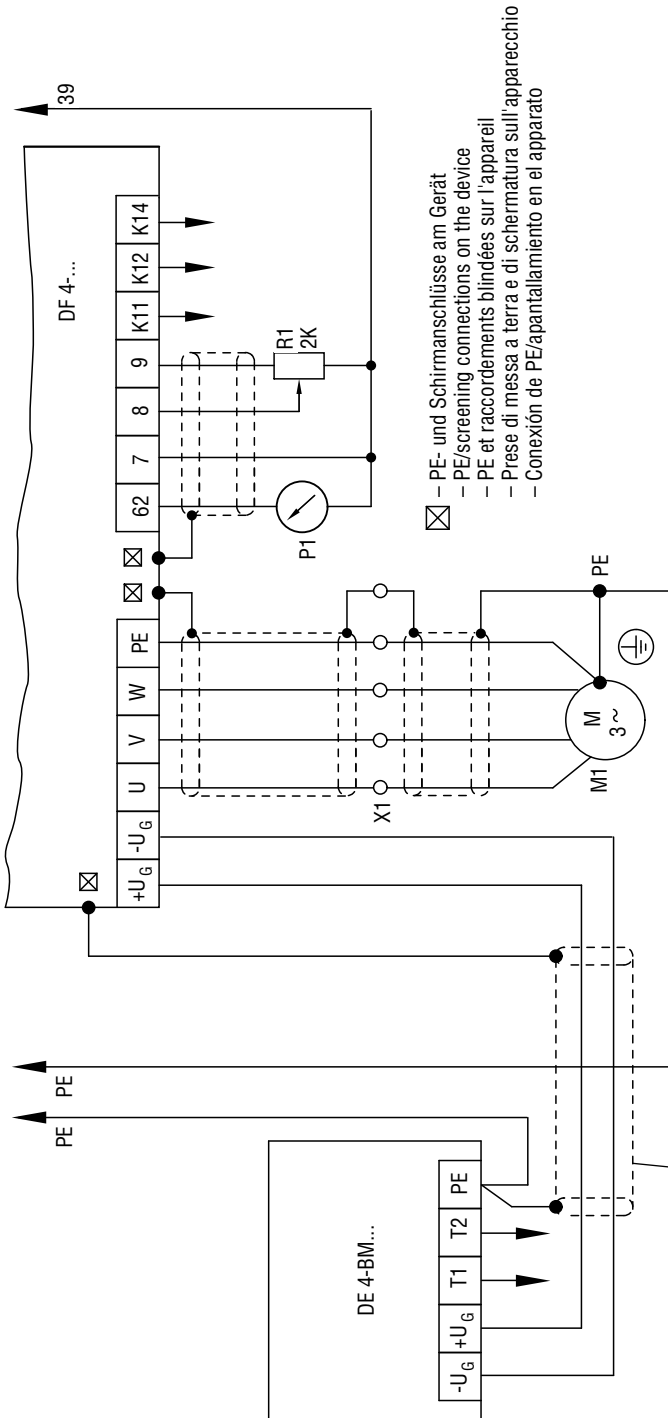

Abgeschirmte Leitung ≥ 300 mm
 Screened cable ≥ 300 mm
 Câble blindé ≥ 300 mm
 Conduttore schermato ≥ 300 mm
 Cable apantallado ≥ 300 mm

