

CAN PT (system bus)

CAN PT (system bus)	Order ref.	E82ZAFCC010
CAN (system bus)	Order ref.	E82ZAFCC

The CAN (system bus) function module can be used to interface the 8200 vector with the CAN (Controller Area Network) serial communication system. Plug-in spring-clamp terminals enable cable cross-sections of up to 1.5 mm² to be connected quickly and easily without the need for ferrules. Due to the plugged-on spring-clamp terminal strip, the function module juts out approx. 15 mm of the front panel of the frequency inverter. For the purposes of simple diagnostics, dual screw terminals can be used to interrupt communication with the frequency inverter without affecting the bus operation of other devices. The module is also available in a basic version without plug-in terminal.

The function module enables the 8200 vector to perform additional functions, including:

- Parameter preselection/remote parameter setting
- Data transfer between inverters
- Connection to external control systems (e.g. drive PLC) and host systems
- Optional connection to
 - distributed terminal extensions (see also page 3-42)
 - keypads

Terminal assignment

X3.1/	Name	Function
7	GND1	Reference potential 1
LO	CAN-LOW	System bus LOW (data cable)
HI	CAN-HIGH	System bus HIGH (data cable)
X3.2/		
7	GND1	Reference potential 1
39	GND2	Reference potential 2 for controller inhibit (CINH) at X3.2/28
28	CINH	Controller inhibit <ul style="list-style-type: none"> • Start = HIGH (+12 V...+30 V) • Stop = LOW (0 V ... +3 V)
20		DC voltage source for internal supply for controller inhibit (CINH) +20 V (reference: GND1)

Supply: Controller inhibit terminal (X3/28) via internal voltage supply

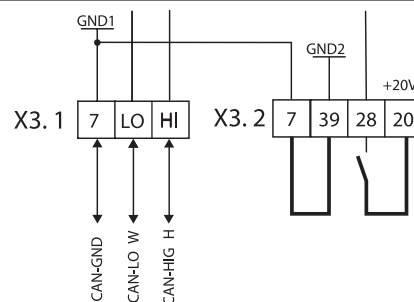

Supply: Controller inhibit terminal (X3/28) via external voltage supply

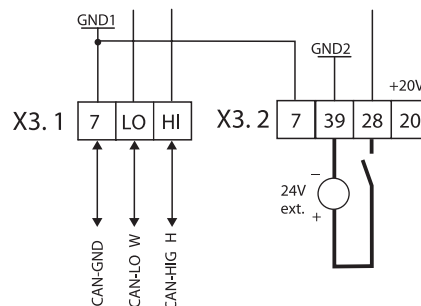





— Minimum wiring required for operation



CAN PT (system bus)

General data and application conditions

Communication medium	DIN ISO 11898				
Communication profile	Similar to CANopen (CiA DS301)				
Network topology	Line (terminated at both ends with 120 Ω)				
System bus device	Master or slave				
Max. number of devices	63				
Baud rate [kBit/s]	20	50	125	250	500
Max. bus length [m] ³⁾	3910	1510	590	250	80
Number of logical process data channels	2				
Number of logical parameter data channels	2				
Electrical connection	Push-on terminal strips with spring-clamp connection and dual screw connection				
Connection options		Rigid: 1.5 mm ² (AWG 16)			
	Flexible:				
		1.5 mm ² (AWG 16) without ferrules			
		1.5 mm ² (AWG 16) with ferrules without plastic sleeve			
	0.5 mm ² (AWG 20) with ferrules with plastic sleeve ¹⁾				
	1.5 mm ² (AWG 16) with ferrules with plastic sleeve ²⁾				
DC supply to the function module	Internal				
Insulation voltage to reference earth/PE	50 V AC				
Ambient temperature	Operation: -20 ... +60°C Transport: -25 ... +70°C Storage: -25 ... +60°C				
Climatic conditions	Class 3K3 to EN 50178 (without condensation, average relative humidity 85%)				

¹⁾ Spring-clamp connection

²⁾ Dual screw connection

³⁾ You should be aware of the additional effect of the number of devices and the cable cross-section used on the maximum bus cable lengths.

Note:

Two bus terminating resistors (120 Ω) are included in the scope of supply.

Wiring notes

We recommend the following signal cable:

System bus cable specification	Total length up to 300 m	Total length up to 1000 m
Cable type	LIYCY 2 x 2 x 0.5 mm ² (shielded twisted pairs)	CYPIMF 2 x 2 x 0.5 mm ² (shielded twisted pairs)
Cable resistance	≤ 40 Ω/km	≤ 40 Ω/km
Capacitance per unit length	≤ 130 nF/km	≤ 60 nF/km
Connection	Pair 1 (white/brown): CAN-LOW and CAN-HIGH Pair 2 (green/yellow): CAN-GND	