

Information for the operator of the machine

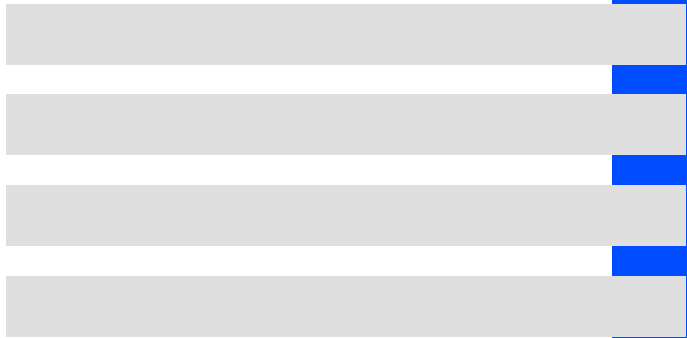

9300 45 ... 75 kW

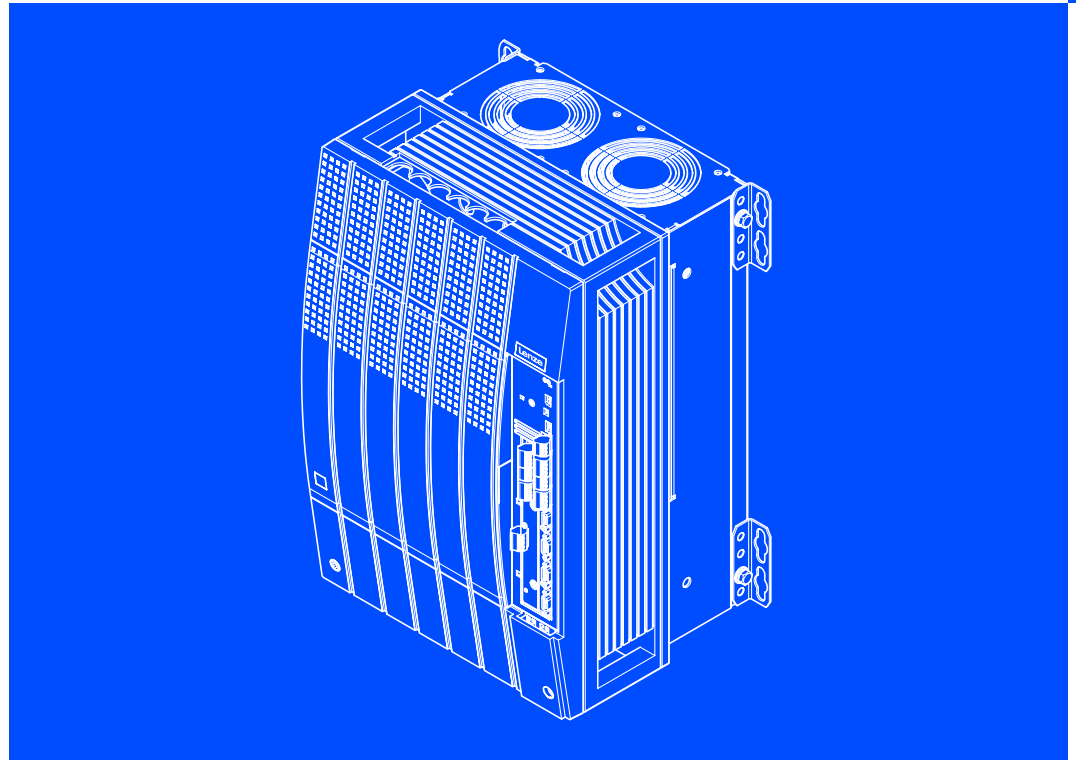

EVS9330 ... EVS9332

Servo controller

LenzePartsOnline.com

This documentation applies to ...

... 9300 servo controllers as of nameplate data:

		①	②	③	Nameplate				
		EVS	93xx	-	x	x	Vxx	1x	xx
Product series									
EVS =		Servo controller							
Type no. / rated power									
		400 V	480 V						
9330 =		45 kW	45 kW						
9331 =		55 kW	55 kW						
9332 =		75 kW	90 kW						
Type									
E =		Panel-mounted unit							
C =		Built-in unit in "cold plate" technique							
Design									
I =		Servo PLC							
K =		Servo cam							
P =		Servo position controller							
R =		Register controller							
S =		Servo inverter							
T =		Servo PLC technology							
Variant									
-		Standard							
V003 =		In "cold plate" technique							
V004 =		With "safe standstill" function							
V100 =		For IT mains							
V104 =		With "safe standstill" function and for IT mains							
Hardware version									
Software version									

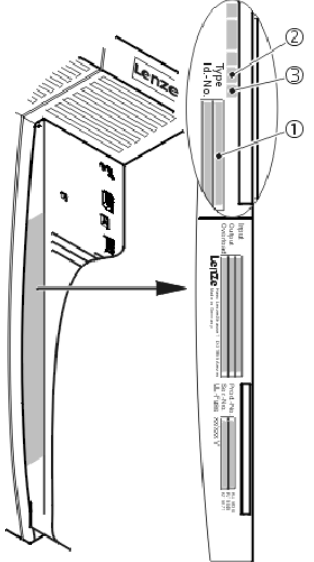

9300vec112



Note!

This documentation contains all necessary information for the machine operator to be able to operate the servo controllers of the 9300 series installed in your machine/plant. You can make further use of all information in this documentation without consulting Lenze if you do not make any changes to the contents.



Tip!

Current documentation and software updates concerning Lenze products can be found on the Internet in the "Services & Downloads" area under <http://www.Lenze.com>

LenzePartsOnline.com

© 2008 Lenze Drive Systems GmbH, Hans-Lenze-Straße 1, D-31855 Aerzen

We have compiled all information in this documentation with great care and have checked it with regard to compliance with the hardware and software described. Nevertheless, we cannot entirely exclude deviations. We do not accept legal responsibility or liability for damage possibly resulting therefrom. We will include necessary amendments in the subsequent editions.

EVS9330

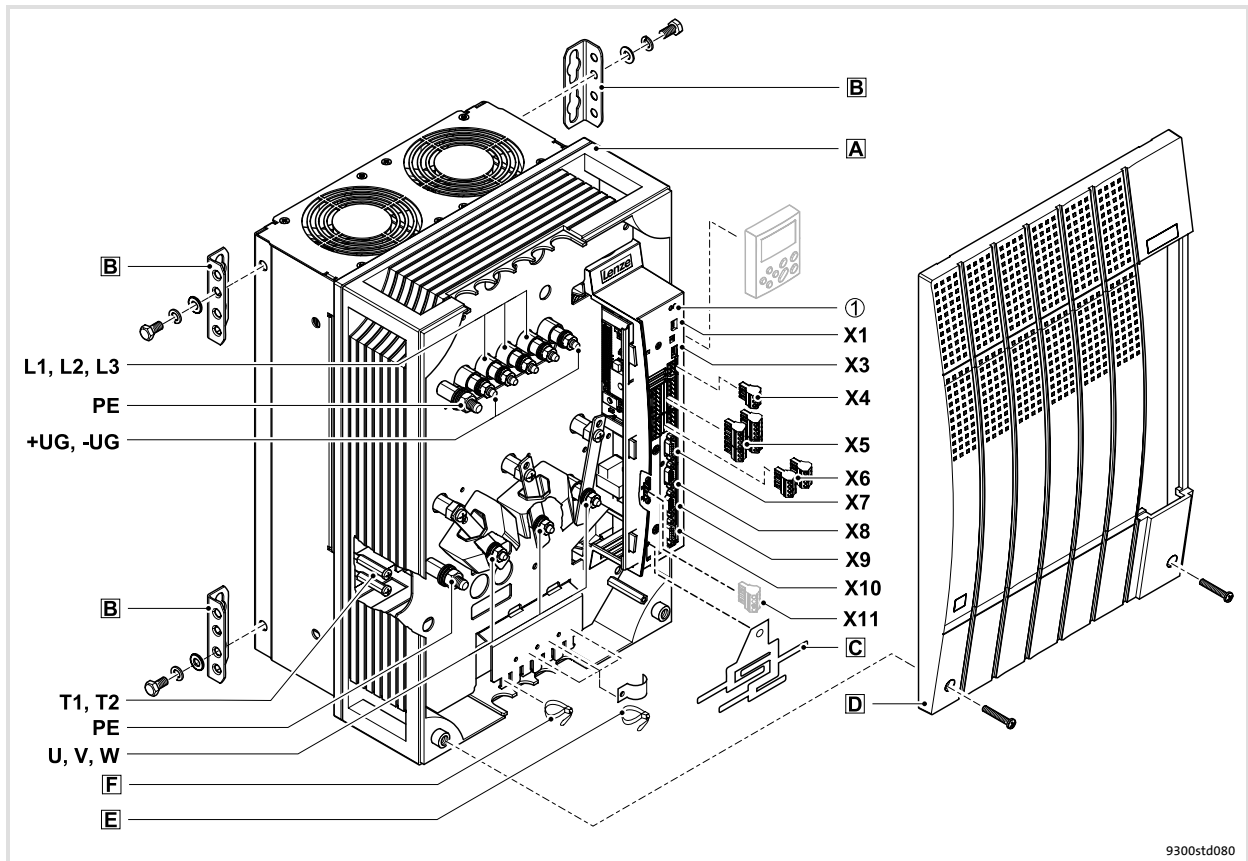

EVS9331, EVS9332

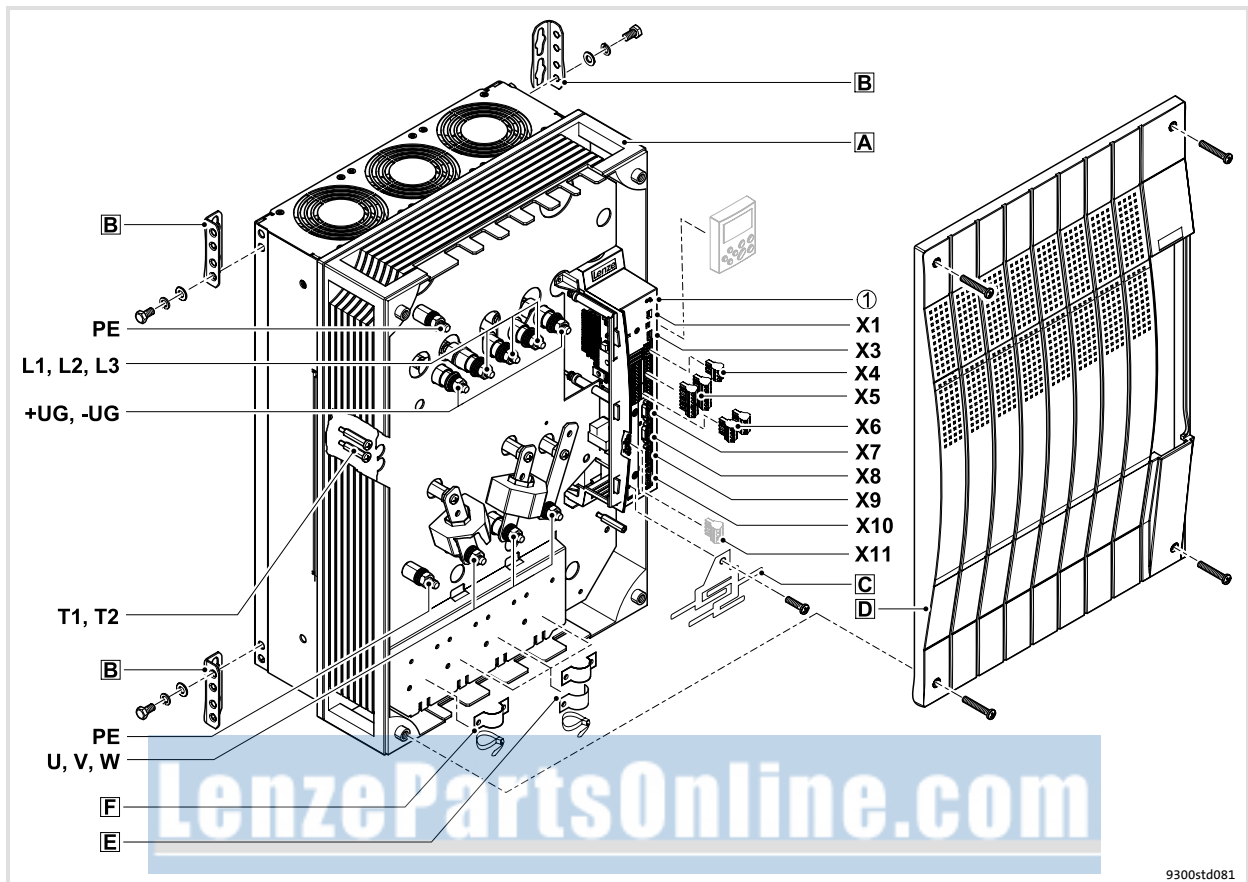

Key for overview

Position	Description
A	Controller
B	Fixing bracket for standard mounting
C	EMC shield sheet with fixing screws for shielded control cables
D	Cover with fixing screws
E	Shield clamp and strain relief for the motor cable
F	Strain relief for the PE motor cable and the feed cable for the motor temperature monitoring with PTC thermistor or thermal contact (NC contact)

Connections and interfaces

Position	Description
L1, L2, L3, PE	Mains connection
+UG, -UG	DC supply
U, V, W, PE	Motor connection
T1, T2	Connection of PTC thermistor or thermal contact (NC contact) of the motor
X1	AIF interface (automation interface) Slot for communication module (e. g. XT EMZ9371BC keypad)
X3	Jumper for setting analog input signal at X6/1, X6/2
X4	Terminal strip for system bus (CAN) connection
X5	Terminal strips for connection of digital inputs and outputs
X6	Terminal strips for connection of analog inputs and outputs
X7	Sub-D connector (female) for connection of resolver and KTY temperature sensor of the motor
X8	Sub-D connector (male) for connection of incremental encoder with TTL level or SinCos encoder and KTY temperature sensor of the motor
X9	Sub-D connector (male) for connection of digital frequency input signal
X10	Sub-D connector (female) for connection of digital frequency output signal
X11	Terminal strip for connection of K _{SR} relay output for "safe standstill" (for variants V004 and V024 only)

Status displays

Position	LED red	LED green	Operating status
①	Off	On	Controller enabled
	On	On	Mains is switched on and automatic start is inhibited
	Off	Blinking slowly	Controller inhibited
	Blinking quickly	Off	Undervoltage or overvoltage
	Blinking slowly	Off	Active fault

1	Safety instructions	7
1.1	General safety and application notes for Lenze controllers	7
1.2	Residual hazards	10
1.3	Definition of notes used	12
2	Parameter setting	13
2.1	Parameter setting with the XT EMZ9371BC keypad	13
2.1.1	General data and operating conditions	13
2.1.2	Installation and commissioning	14
2.1.3	Display elements and function keys	14
2.1.4	Changing and saving parameters	16
2.1.5	Loading a parameter set	18
2.1.6	Transferring parameters to other standard devices	19
2.1.7	Activating password protection	21
2.1.8	Diagnostics	22
2.1.9	Menu structure	23
3	Troubleshooting and fault elimination	25
3.1	Display of operating data, diagnostics	25
3.2	Troubleshooting	26
3.2.1	Status display (LEDs on the controller)	26
3.2.2	Fault analysis with the history buffer	27
3.2.3	Fault analysis via LECOM status words (C0150/C0155)	28
3.3	System error messages	29
3.3.1	General error messages	29
3.3.2	Resetting system error messages	37

LenzePartsOnline.com

1 Safety instructions

1.1 General safety and application notes for Lenze controllers

(in accordance with Low-Voltage Directive 2006/95/EC)

For you personal safety

During the operation, Lenze controllers (frequency inverters, servo inverters, DC speed controllers) and their associated components can hold live as well as moving or rotary parts, according to their degree of protection. Surfaces may be hot.

Non-authorized removal of the required cover, inappropriate use, faulty installation or incorrect operation creates the risk of severe injury to persons or damage to material assets.

More information can be obtained from the documentation.

High amounts of energy are released in the controller. Thus, it is required to always wear a personal protective equipment (body protection, headgear, eye protection, ear protection, hand guard).

All operations concerning transport, installation, and commissioning as well as maintenance must be carried out by qualified, skilled personnel (IEC 364 and CENELEC HD 384 or DIN VDE 0100 and IEC report 664 or DIN VDE 0110 and national regulations for the prevention of accidents must be observed).

According to this basic safety information, qualified, skilled personnel are persons who are familiar with the assembly, installation, commissioning, and operation of the product and who have the qualifications necessary for their occupation.

Application as directed

Drive controllers are components which are designed for the installation in electrical systems or machinery. They are not to be used as household appliances. They are intended exclusively for professional and commercial purposes according to EN 61000-3-2.

When installing the controllers into machines, the commissioning (i.e. starting of operation as directed) is prohibited until it is proven that the machine complies with the regulations of the EC Directive 98/37/EC (Machinery Directive); EN 60204 must be observed.

Commissioning (i.e. starting of operation as directed) is only allowed when there is compliance with the EMC Directive (89/336/EWG).

The controllers meet the requirements of the Low-Voltage Directive 2006/95/EC. The harmonised standard EN 61800-5-1 applies to the controllers.

The technical data and information on connection conditions must be obtained from the nameplate and the documentation. They must be observed in any case.

Warning: The controllers can be used according to EN 61800-3 in drive systems of the category C2. These products can cause radio interferences in residential areas. In this case, special measures are required.

Transport, storage

Please observe the notes on transport, storage and appropriate handling. Observe the climatic conditions according to the technical data.

Installation

The controllers must be installed and cooled according to the instructions given in the corresponding documentation.

Ensure proper handling and avoid mechanical stress. Do not bend any components and do not change any insulation distances during transport or handling. Do not touch any electronic component or contact.

Controllers contain electrostatically sensitive components which can easily be damaged by inappropriate handling. Do not damage or destroy any electrical component since this might endanger your health!

Electrical connection

When working on live controllers, the valid national regulations for the prevention of accidents (e.g. VBG 4) must be observed.

The electrical installation must be carried out according to the appropriate regulations (e.g. cable cross-sections, fuses, PE connection). Additional information can be obtained from the documentation.

The documentation contains information on installation in compliance with EMC (shielding, earthing, filter arrangement, and cable installation). These notes must also be observed for CE-marked controllers. The manufacturer of the system or machine is responsible for ensuring compliance with the limit values demanded by the EMC legislation. The controllers must be installed in housings (e.g. control cabinets) to comply with the limit values for radio interferences valid at the site of installation. The housings must enable an EMC-compliant installation. Make sure in particular that e.g. the control cabinet doors have a circumferential metal connection to the housing. Reduce housing openings and cutouts to a minimum.

Lenze controllers can cause a DC current in the protective conductor. If a residual current device (RCD) is used as a protective means in case of direct or indirect contact, only a residual current device (RCD) of type B may be used on the current supply side of the controller. Otherwise, another protective measure, such as separation from the environment through double or reinforced insulation or disconnection from the mains by means of a transformer, must be used.

Operation

If necessary, systems including controllers must be equipped with additional monitoring and protection devices according to the valid safety regulations (e.g. law on technical equipment, regulations for the prevention of accidents). The controllers can be adapted to your application. Please observe the corresponding information given in the documentation.

After a controller has been disconnected from the voltage supply, all live components and power connections must not be touched immediately because capacitors may still be charged. Please observe the corresponding stickers on the controller.

All protection covers and doors must be shut during operation.

Note for UL approved systems with integrated controllers: UL warnings are notes that only apply to UL systems. The documentation contains special information about UL.

Safety functions

Certain variants of the drive controller support safety functions (e.g. "safe torque off", formerly "safe standstill"), according to the requirements of appendix I No. 1.2.7 of the EC Machinery Directive 98/37/EC, EN 954-1 Category 3 and EN 1037. You must observe the notes pertaining to the safety functions in the documentation to the variants.

Maintenance and servicing

The controllers do not require any maintenance if the prescribed conditions of operation are observed.

If the ambient air is polluted, the cooling surfaces of the controller may become dirty or the air vents of the controller may be obstructed. Therefore, clean the cooling surfaces and air vents periodically under these operating conditions. Do not use sharp or pointed tools for this purpose!

Waste disposal

Recycle metal and plastic materials. Ensure professional disposal of assembled PCBs.

The product-specific safety and application notes given in these instructions must be observed!

LenzePartsOnline.com

1 Safety instructions

Residual hazards

1.2 Residual hazards

Protection of persons

- ▶ Before working on the controller, check that all power terminals are deenergised:
 - The power terminals U, V, W, +U_G and -U_G remain live for at least three minutes after disconnection from the mains.
 - The power terminals L1, L2, L3; U, V, W, +U_G and -U_G remain live when the motor is stopped.
- ▶ The leakage current to earth (PE) is > 3.5 mA. According to EN 50178
 - a fixed installation is required.
 - a double PE connection is required or, if in single design, it must have a cable cross-section of at least 10 mm².
- ▶ The heatsink of the controller has an operating temperature of > 80 °C:
 - Contact with the heatsink results in burns.
- ▶ During parameter set transfer the control terminals of the controller can have undefined states.
 - Therefore the connectors X5 and X6 must be disconnected from the controller before the transfer takes place. This ensures that the controller is inhibited and all control terminals have the defined state "LOW".

Device protection

- ▶ Frequent mains switching (e.g. inching mode via mains contactor) can overload and destroy the input current limitation of the drive controller:
 - For this reason at least 3 minutes have to pass between two starting operations.
 - Use the "safe torque off" safety function (STO) if safety-related mains disconnections occur frequently. The drive variants Vxx4 are equipped with this function.

Protection of the machine/system

- ▶ Drives can reach dangerous overspeeds (e. g. setting of high output frequencies in connection with motors and machines not suitable for this purpose):
 - The drive controllers do not provide protection against such operating conditions. For this purpose, use additional components.

LenzePartsOnline.com



Warnings!

- ▶ The device has no overspeed protection.
- ▶ Must be provided with external or remote overload protection.
- ▶ Maximum surrounding air temperature: 50 °C
- ▶ Use 60/75 °C or 75 °C copper wire only.
- ▶ Please observe the specifications for fuses and screw-tightening torques in these instructions.
- ▶ EVS9321 ... EVS9329:
Suitable for use on a circuit capable of delivering not more than 5000 rms symmetrical amperes, 480 V maximum.
- ▶ EVS9330 ... EVS9332:
Suitable for use on a circuit capable of delivering not more than 10000 rms symmetrical amperes, 480 V maximum.

LenzePartsOnline.com

1 Safety instructions

Definition of notes used

1.3 Definition of notes used

The following pictographs and signal words are used in this documentation to indicate dangers and important information:

Safety instructions

Structure of safety instructions:





Danger!



(characterises the type and severity of danger)

Note

(describes the danger and gives information about how to prevent dangerous situations)

Pictograph and signal word	Meaning
 Danger!	Danger of personal injury through dangerous electrical voltage. Reference to an imminent danger that may result in death or serious personal injury if the corresponding measures are not taken.
 Danger!	Danger of personal injury through a general source of danger. Reference to an imminent danger that may result in death or serious personal injury if the corresponding measures are not taken.
 Stop!	Danger of property damage. Reference to a possible danger that may result in property damage if the corresponding measures are not taken.

Application notes

Pictograph and signal word	Meaning
 Note!	Important note to ensure troublefree operation
 Tip!	Useful tip for simple handling
 Reference!	Reference to another documentation

LenzePartsOnline.com

2 Parameter setting

2.1 Parameter setting with the XT EMZ9371BC keypad

Description

The keypad is available as an accessory. A full description of the keypad can be obtained from the Instructions included in the keypad delivery.

Plugging in the keypad

It is possible to plug the keypad into the AIF interface or remove it during operation.

As soon as the keypad is supplied with voltage, it carries out a self-test. The keypad is ready for operation if it is in display mode.

2.1.1 General data and operating conditions

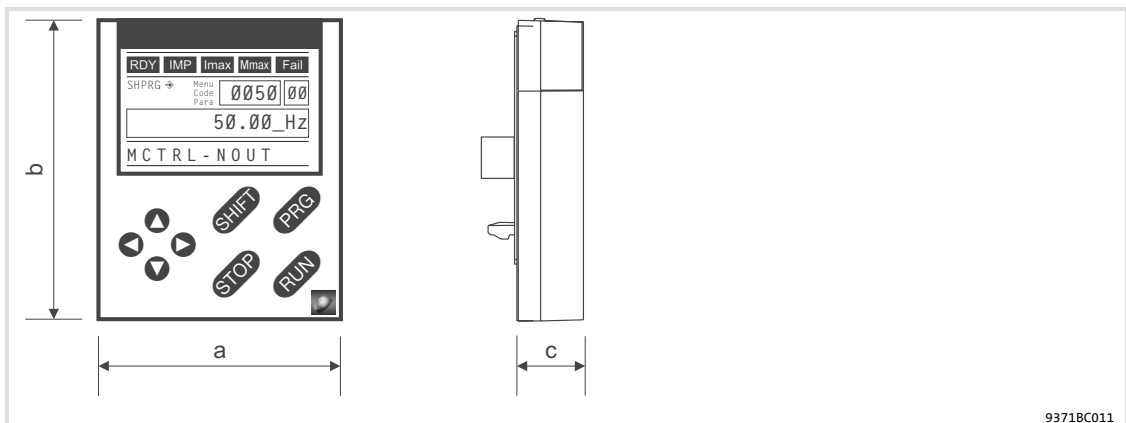

Feature	Values	
Dimensions		
Width	a	60 mm
Height	b	73.5 mm
Depth	c	15 mm
Environmental conditions		
Climate		
Storage	IEC/EN 60721-3-1	1K3 (-25 ... +60 °C)
Transport	IEC/EN 60721-3-2	2K3 (-25 ... +70 °C)
Operation	IEC/EN 60721-3-3	3K3 (-10 ... +60 °C)
Enclosure	IP 20	



2.1.2 Installation and commissioning

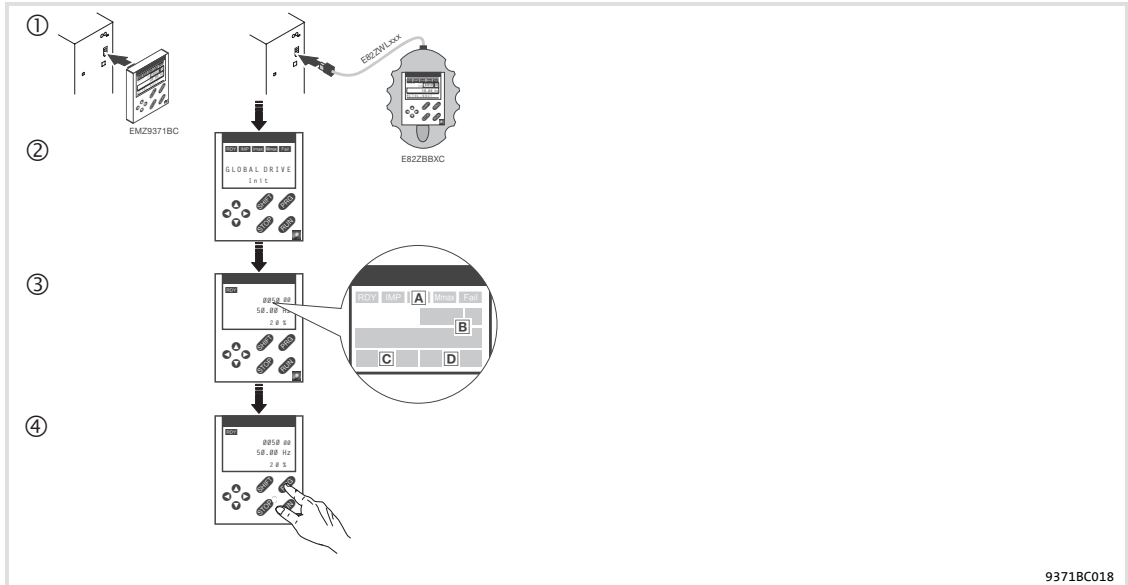

Fig.2-1 Installation and commissioning of XT EMZ9371BC keypad or E82ZBBXC diagnosis terminal

- ① Connect keypad to the AIF interface on the front of the standard device.
The keypad can be connected/disconnected during operation.
- ② As soon as the keypad is supplied with voltage, it carries out a short self-test.
- ③ The operation level indicates when the keypad is ready for operation:
 - A Current state of the standard device
 - B Memory location 1 of the user menu (C0517):
Code number, subcode number, and current value
 - C Active fault message or additional status message
 - D Actual value in % of the status display defined in C0004
- ④ **PRG** must be pressed to leave the operation level

2.1.3 Display elements and function keys

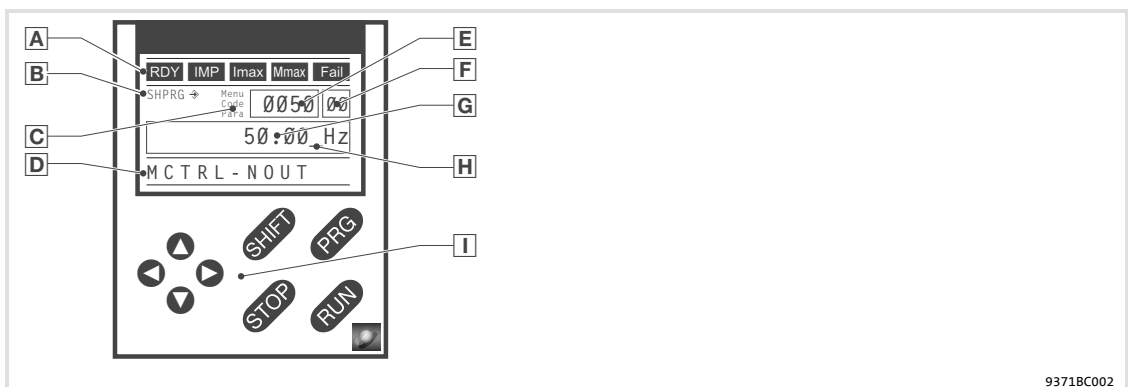

Fig.2-2 Display elements and function keys of the XT EMZ9371BC keypad



Displays

Display	Meaning	Explanation
A Status displays of standard device		
RDY	Ready for operation	
IMP	Pulse inhibit is active	Power outputs are inhibited
Imax	Set current limit is exceeded in motor or generator mode	
Mmax	Speed controller 1 in its limitation	Drive is torque-controlled (Only active for operation with standard devices of 9300 series)
Fail	Active fault	
B Parameter acceptance		
↔	Parameter is accepted immediately	Standard device operates immediately with the new parameter value
SHPRG ↔	Parameter must be confirmed with SHIFT PRG	Standard device operates with the new parameter value after being confirmed
SHPRG	When the controller is inhibited the parameter must be confirmed with SHIFT PRG	Standard device operates with the new parameter value after the controller is re-enabled
None	Display parameter	Change is not possible
C Active level		
Menu	Menu level is active	Select main menu and submenus
Code	Code level is active	Select codes and subcodes
Para	Parameter level is active	Change parameters in the codes or subcodes
None	Operating level is active	Display operating parameters
D Short text		
Alphanumeric	Contents of the menus, meaning of the codes and parameters In the operating level C0004 (in %) and the active fault are displayed	
E Number		
Menu level	With active level: Menu number	Only active for operation with standard devices of 8200 vector or 8200 motec series
Code level	With active level: Four-digit code number	
F Number		
Menu level	With active level: Submenu number	Only active for operation with standard devices of 8200 vector or 8200 motec series
Code level	With active level: Two-digit subcode number	
G Parameter value		
	Parameter value with unit	
H Cursor		
		In the parameter level, the figure above the cursor can be changed directly
I Function keys		
		For description see the following table

LenzePartsOnline.com

Parameter setting

Parameter setting with the XT EMZ9371BC keypad
Changing and saving parameters

Function keys



Note!

Key combinations with **SHIFT**:

Press **SHIFT** and keep it pressed, then press the second key in addition.

Key	Function			
	Menu level	Code level	Parameter level	Operating level
PRG		Change to the parameter level	Change to the operating level	Change to the code level
SHIFT PRG	Load predefined configurations in the menu "Short setup" ¹⁾		Accept parameters when SHPRG ⇄ or SHPRG is displayed	
▲ ▼	Change between menu items	Change of code number	Change of figure above cursor	
SHIFT ▲ SHIFT ▼	Quick change between the menu items	Quick change of code number	Quick change of figure above cursor	
▶ ◀	Change between main menu, submenus and code level		Cursor to the right Cursor to the left	
RUN	Cancel the function of STOP key, the LED in the key is off			
STOP	Inhibit controller, the LED in the key is lit			
	Reset the fault (TRIP reset):	1. Remedy the cause of malfunction 2. Press STOP 3. Press RUN		

¹⁾ Only active for operation with standard devices of 8200 vector or 8200 motec series

2.1.4

Changing and saving parameters



Note!

Your settings have an effect on the current parameters in the main memory. You must save your settings in a parameter set so that they are not lost when the mains are connected.

If you only need one parameter set, save your settings as parameter set 1, since parameter set 1 is loaded automatically after mains connection.

Step	Key sequence	Action
1. Select the menu	▲ ▶ ▶ ▶	Use the arrow keys to select the desired menu
2. Change to the code level	▶	Display of the first code in the menu
3. Select code or subcode	▼ ▲	Display of the current parameter value
4. Change to the parameter level	PRG	
5. When SHPRG is displayed, inhibit the controller	STOP ¹⁾	The drive coasts
6. Change parameter		
	A ▶ ▶	Move cursor below the figure to be changed
	B ▼ ▲	Change of figure
	SHIFT ▼ SHIFT ▲	Quick change of figure
7. Accept the changed parameter		

Step	Key sequence	Action
	Display of SHPRG or SHPRG →	SHIFT PRG
	Display →	-
8.	Enable the controller, if required	RUN 1)
9.	Change to the code level	
	A	PRG
	B	PRG
10.	Change further parameters	
11.	Save changed parameters	
	A	▲ ▼ ▶ ◀
	B	PRG
	C	▲
	D	SHIFT PRG
12.	Change to the code level	
	A	PRG
	B	PRG
13.	Set parameters for another parameter set	

1) The function of the STOP key can be programmed:
C0469 = 1: Controller inhibit
C0469 = 2: Quick stop (Lenze setting)

Parameter setting

Parameter setting with the XT EMZ9371BC keypad
Loading a parameter set

2.1.5 Loading a parameter set

The keypad serves to load a saved parameter set into the main memory when the controller is inhibited. After the controller is enabled, it operates with the new parameters.













Danger!

- ▶ When a new parameter set is loaded, the controller is reinitialised and acts as if it had been connected to the mains:
 - System configurations and terminal assignments can be changed. Make sure that your wiring and drive configuration comply with the settings of the parameter set.
- ▶ Only use terminal X5/28 as source for the controller inhibit! Otherwise the drive may start in an uncontrolled way when switching over to another parameter set.



Note!

- ▶ After switching on the supply voltage, the controller always loads parameter set 1 into the main memory.
- ▶ It is also possible to load other parameter sets into the main memory via the digital inputs or bus commands.

Step		Key sequence	Action
1.	Inhibit controller		Terminal X5/28 = LOW
2.	Load the saved parameter set into the main memory		
		A    	Select the code C0002 "PAR LOAD" in the menu "Load/Store"
		B 	Change to the parameter level The active parameter set is displayed, e. g. display "0" and "Load Default" If you want to restore the delivery status, proceed with D
	Select the parameter set to be loaded	C 	Load parameter set 1: ⇒ Set "1" "Load PS1" Load parameter set 2: ⇒ Set "2" "Load PS2" Load parameter set 3: ⇒ Set "3" "Load PS3" Load parameter set 4: ⇒ Set "4" "Load PS4"
		D  	"RDY" goes off. The parameter set is loaded completely into the main memory if "RDY" is displayed again.
3.	Change to the code level		
		A 	Display of the operating level
		B 	Display of C0002 "PAR LOAD"
4.	Enable controller		Terminal X5/28 = HIGH The drive is running with the settings of the loaded parameter set

2.1.6 Transferring parameters to other standard devices

The keypad enables you to copy parameter settings from one standard device to another. For this purpose use the "Load/Store" menu:



Danger!

During the transfer of the parameters from the keypad to the controller, the control terminals may adopt undefined states!

Therefore be absolutely sure to disconnect the connectors X5 and X6 from the controller prior to the transfer. Like this you will ensure that the drive controller is inhibited and all control terminals are in the defined "LOW" state.

Copying parameter sets from the standard device to the keypad



Note!

After the parameter sets are copied to the keypad XT (C0003 = 11), the parameter set last loaded using C0002 is always activated.

So the actual parameters remain active also after copying:

- ▶ Prior to copying, save the actual parameters in the parameter set and load this parameter set into the drive controller using C0002.

Step	Key sequence	Action
1.	Connect keypad to controller 1	
2.	Inhibit controller	Terminal X5/28 = LOW The drive coasts.
3.	On the "Load/Store" menu select C0003	On the "Load/Store" menu select code C0003 "PAR SAVE" using the arrow keys.
4.	Change to the parameter level	Display "0" and "READY"
5.	Copy all parameter sets to the keypad	The settings stored in the keypad are overwritten. Set "11" "Save extern"
6.	Start copying	The "RDY" status display goes off. "BUSY" is indicated as parameter value. When "BUSY" goes off after approx. one minute, all parameter sets have been copied to the keypad. The "RDY" status display illuminates.
7.	Change to the code level	
	A	Display of the operating level
	B	Display of C0003 and "PAR SAVE"
8.	Enable controller	Terminal X5/28 = HIGH
9.	Remove keypad from controller 1	



Parameter setting

Parameter setting with the XT EMZ9371BC keypad
Transferring parameters to other standard devices

Copying parameter sets from the keypad to the standard device

Step	Key sequence	Action
1.	Connect keypad to controller 2	
2.	Inhibit controller	Terminal X5/28 = LOW The "IMP" status display illuminates. The drive coasts
3.	Disconnect connectors X5 and X6	All control terminals have the defined "LOW" state.
4.	On the "Load/Store" menu select C0002	On the "Load/Store" menu select code C0002 "PAR LOAD" using the arrow keys.
5.	Change to the parameter level	The active parameter set is displayed, e. g. display "0" and "Load Default"
6.	Select the correct copy function	The settings stored in the controller are overwritten.
	<ul style="list-style-type: none"> Copy all available parameter sets to the controller and save in non-volatile memory. 	The parameters are not yet active after copying. Select parameter set and load into main memory. 18
		Set "20" "ext -> EEPROM"
	<ul style="list-style-type: none"> Copy individual parameter sets to main memory. 	
		Copy parameter set 1: ⇒ Set "11" "Load ext PS1"
		Copy parameter set 2: ⇒ Set "12" "Load ext PS2"
		Copy parameter set 3: ⇒ Set "13" "Load ext PS3"
		Copy parameter set 4: ⇒ Set "14" "Load ext PS4"
7.	Start copying	The "RDY" status display goes off. "BUSY" is indicated as parameter value. When "BUSY" goes off, all selected parameter sets have been copied to the controller. The "RDY" status display illuminates.
8.	Change to the code level	
	A	Display of the operating level
	B	Display of C0002 and "PAR LOAD"
9.	Save individually copied parameter sets in non-volatile memory	On the "Load/Store" menu select code C0003 "PAR SAVE" using arrow keys and save contents of the main memory in non-volatile memory.
10.	Connect connectors X5 and X6	
11.	Enable controller	Terminal X5/28 = HIGH The drive runs with the new settings.

LenzePartsOnline.com

2.1.7 Activating password protection



Note!

- ▶ If the password protection is activated (C0094 = 1 ... 9999), you only have free access to the user menu.
- ▶ To access the other menus, you must enter the password. By this, the password protection is annulled until you enter a new password.
- ▶ Please observe that the password-protected parameters can be overwritten as well when transferring the parameter sets to other standard devices. The password is not transferred.
- ▶ Do not forget your password! If you have forgotten your password, it can only be reset via a PC or a bus system!

Activate password protection

Step	Key sequence	Action
1. Select the "USER menu"	⬅ ➡ ⬆ ⬇	Change to the user menu using the arrow keys
2. Change to the code level	➡	Display of code C0051 "MCTRL-NACT"
3. Select C0094	⬆	Display of code C0094 "Password"
4. Change to the parameter level	PRG	Display "0" = no password protection
5. Set password	A ⬆	Select password (1 ... 9999)
	B SHIFT PRG	Confirm password
6. Change to the code level	A PRG	Display of the operating level
	B PRG	Display of C0094 and "Password"
7. Change to the "USER menu"	⬅ ⬆ ⬇	

The password protection is active now.

You can only quit the user menu if you re-enter the password and confirm it with **SHIFT PRG**.

Remove password protection

Step	Key sequence	Action
1. Change to the code level in the user menu	➡	
2. Select C0094	⬆	Display of code C0094 "Password"
3. Change to the parameter level	PRG	Display "9999" = password protection is active
4. Enter password	A ⬇	Set valid password
	B SHIFT PRG	Confirm The password protection is deactivated by entering the password once again.
5. Change to the code level	A PRG	Display of the operating level
	B PRG	Display of C0094 and "Password"

The password protection is deactivated now. All menus can be freely accessed again.

2.1.8 Diagnostics

In the "Diagnostic" menu the two submenus "Actual info" and "History" contain all codes for

- ▶ monitoring the drive
- ▶ fault/error diagnosis

In the operating level, more status messages are displayed. If several status messages are active, the message with the highest priority is displayed.

Priority	Display	Meaning
1	GLOBAL DRIVE INIT	Initialisation or communication error between keypad and controller
2	XXX - TRIP	Active TRIP (contents of C0168/1)
3	XXX - MESSAGE	Active message (contents of C0168/1)
4	Special device states:	
		Switch-on inhibit
5	Source for controller inhibit (the value of C0004 is displayed simultaneously):	
	STP1	9300 servo: Terminal X5/28 ECSxS/P/M/A: Terminal X6/SI1
	STP3	Operating module or LECOM A/B/LI
	STP4	INTERBUS or PROFIBUS-DP
	STP5	9300 servo, ECSxA/E: System bus (CAN) ECSxS/P/M: MotionBus (CAN)
	STP6	C0040
6	Source for quick stop (QSP):	
	QSP-term-Ext	The MCTRL-QSP input of the MCTRL function block is on HIGH signal.
	QSP-C0135	Operating module or LECOM A/B/LI
	QSP-AIF	INTERBUS or PROFIBUS-DP
	QSP-CAN	9300 servo, ECSxA: System bus (CAN) ECSxS/P/M: MotionBus (CAN)
7	XXX - WARNING	Active warning (contents of C0168/1)
8	xxxx	Value below C0004

2.1.9 Menu structure

For simple, user-friendly operation, the codes are clearly arranged in function-related menus:

Main menu	Submenus	Description
Display	Display	
User-Menu		Codes defined in C0517
Code list		All available codes
	ALL	All available codes listed in ascending order (C0001 ... C7999)
	PS 1	Codes in parameter set 1 (C0001 ... C1999)
	PS 2	Codes in parameter set 2 (C2001 ... C3999)
	PS 3	Codes in parameter set 3 (C4001 ... C5999)
	PS 4	Codes in parameter set 4 (C6001 ... C7999)
Load/Store		Parameter set management Parameter set transfer, restore delivery status
Diagnostic		Diagnostic
	Actual info	Display codes to monitor the drive
	History	Fault analysis with history buffer
Short setup		Quick configuration of predefined applications Configuration of the user menu The predefined applications depend on the type of the standard device (frequency inverter, servo inverter, position controller, ...)
Main FB		Configuration of the main function blocks
	NSET	Setpoint processing
	NSET-JOG	Fixed setpoints
	NSET-RAMP1	Ramp function generator
	MCTRL	Motor control
	DFSET	Digital frequency processing
	DCTRL	Internal control
Terminal I/O		Connection of inputs and outputs with internal signals
	AIN1 X6.1/2	Analog input 1
	AIN2 X6.3/4	Analog input 2
	AOUT1 X6.62	Analog output 1
	AOUT2 X6.63	Analog output 2
	DIGIN	Digital inputs
	DIGOUT	Digital outputs
	DFIN	Digital frequency input
	DFOUT	Digital frequency output
	State bus	State bus (not with 9300 frequency inverter)
Controller		Configuration of internal control parameters
	Speed	Speed controller
	Current	Current controller or torque controller
	Phase	Phase controller (not with 9300 frequency inverter)
Motor/Feedb.		Input of motor data, configuration of speed feedback
	Motor adj	Motor data
	Feedback	Configuration of feedback systems
Monitoring		Configuration of monitoring functions

Parameter setting

Parameter setting with the XT EMZ9371BC keypad
Menu structure

Main menu	Submenus	Description
Display	Display	
LECOM/AIF		Configuration of operation with communication modules
	LECOM A/B	Serial interface
	AIF interface	Process data
	Status word	Display of status words
System bus		Configuration of system bus (CAN)
	Management	CAN communication parameters
	CAN-IN1	CAN object 1
	CAN-OUT1	
	CAN-IN2	CAN object 2
	CAN-OUT2	
	CAN-IN3	CAN object 3
	CAN-OUT3	
	Status word	Display of status words
	FDO	Free digital outputs
	Diagnostic	CAN diagnostic
FB config		Configuration of function blocks
Func blocks		Parameterisation of function blocks The submenus contain all available function blocks
FCODE		Configuration of free codes
Identify		Identification
	Drive	Software version of standard device
	Op Keypad	Software version of keypad

LenzePartsOnline.com

3 Troubleshooting and fault elimination

3.1 Display of operating data, diagnostics

The dialog box displays important operating parameters and supports you in diagnosing the drive controller.

- ▶ Open the **Diagnostics** dialog box in the parameter menu.

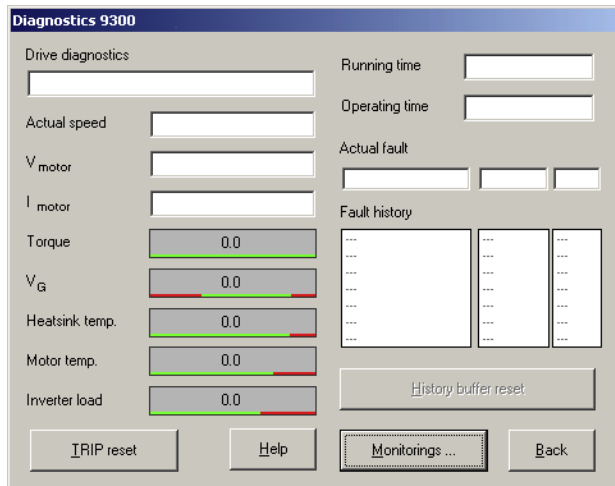

9300std230

Fig.3-1 "Diagnostics" dialog box

- ▶ You can recognise immediately that a fault has occurred from the display elements or status information.
- ▶ An error can be analysed with
 - the history buffer in Global Drive Control (GDC) (📖 27) or
 - the keypad XT
 - and with the "General error messages" table in the "System error messages" chapter.
- ▶ The "General error messages" table provides tips on how to eliminate an error.



3 Troubleshooting and fault elimination

Troubleshooting
Status display (LEDs on the controller)

3.2 Troubleshooting

Failure identification

A failure can be identified quickly by means of the LEDs on the controller or the status information on the keypad.

Error analysis

Errors can be analysed by means of the history buffer. There are helpful hints in the list of fault messages on how to correct them.

3.2.1 Status display (LEDs on the controller)

During operation, the operating status of the controller is indicated by means of two LEDs.

LED		Operating status	
Red ①	Green ②		
Off	On	Controller enabled	
On	On	Mains switched on and automatic start inhibited	
Off	Blinking slowly	Controller inhibited	
Blinking quickly	Off	Undervoltage or overvoltage	
Blinking slowly	Off	Fault active	

LenzePartsOnline.com

3.2.2 Fault analysis with the history buffer

The history buffer can be used to trace faults. The fault messages are stored in the 8 memory locations in the order of their occurrence.

- Open the **Diagnostics** dialog box in the parameter menu.

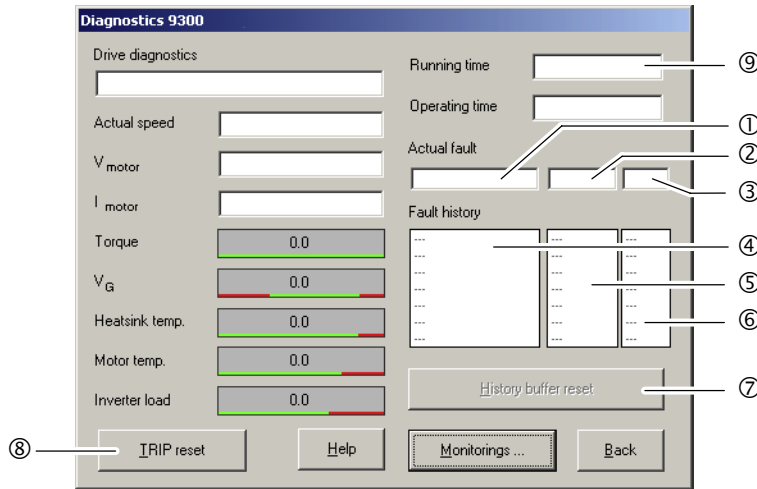

9300std230

Fig.3-2 "Diagnostics" dialog box

Field			Memory location for the history buffer	Entry	Note
①	②	③	1	Active fault	If the fault is not pending any more or was quit: <ul style="list-style-type: none"> • The contents of the memory locations 1 ... 7 are moved up by one memory location. • The contents of memory location 8 drops out of the history buffer and is not available any more. • Memory location 1 is cleared (= no active fault).
			2	Last fault	
			3	Last but two fault	
			4	Last but three fault	
④	⑤	⑥	5	Last but four fault	
			6	Last but five fault	
			7	Last but six fault	
			8	Last but six fault	



Explanations	
①, ④	Fault indication and fault reaction (C0168) <ul style="list-style-type: none"> • The entry is performed as LECOM error number. • If various faults with different reactions occur at the same time: <ul style="list-style-type: none"> – Only one fault is entered whose reaction has the highest priority (1. TRIP, 2. message, 3. warning). • For faults occurring at the same time with the same reaction (e.g. 2 messages): <ul style="list-style-type: none"> – Only the fault that was caused first is entered. • Exception: The OH3 warning has a higher priority than the OH7 warning. <ul style="list-style-type: none"> – A pending OH7 warning is overwritten by the OH3 warning. – After the OH3 warning has gone out, a pending OH7 warning is displayed again.
②, ⑤	Time of the fault (C0169) <ul style="list-style-type: none"> • The reference point is the state of the power-on time meter ②. • If a fault is immediately followed by another fault for several times, only the time of the last occurrence is stored.
③, ⑥	Fault frequency (C0170) <ul style="list-style-type: none"> • The time of the last occurrence is stored.
⑦	Click Fault history reset to clear the history buffer. The history buffer can only be cleared if no fault is active.
⑧	Click TRIP reset to reset the fault.

3.2.3 Fault analysis via LECOM status words (C0150/C0155)

The LECOM status words (C0150/C0155) are coded as follows:

Code		Possible settings		IMPORTANT
No.	Designation	Lenze/ {Appl.}	Selection	
C0150	Status word	0		Status word for networking via automation interface (AIF) Read only
			0 {1} 65535	Controller evaluates information as 16 bits (binary coded)
			Bit 0 Not assigned Bit 1 Pulse inhibit (IMP) is active Bit 2 Not assigned Bit 3 Not assigned Bit 4 Not assigned Bit 5 Not assigned Bit 6 n=0 Bit 7 Controller inhibit (CINH) is active Bit 8 Controller status Bit 9 Controller status Bit 10 Controller status Bit 11 Controller status Bit 12 Warning is active Bit 13 Message is active Bit 14 Not assigned Bit 15 Not assigned	



Code		Possible settings		IMPORTANT
No.	Designation	Lenze/ {Appl.}	Selection	
C0155	Status word 2	0		Status word 2 (advanced status word) Display only
			0 {1} 65535	Controller interprets information as 16 bit (binary coded)
			Bit 0 Active fault Bit 1 M_{max} reached Bit 2 I_{max} reached Bit 3 Pulse inhibit(IMP) Bit 4 Ready for operation (RDY) Bit 5 Controller inhibit (CINH) Bit 6 TRIP active Bit 7 Initialisation Bit 8 Motor direction of rotation (Cw/CCw) Bit 9 Not assigned Bit 10 Not assigned Bit 11 Not assigned Bit 12 Not assigned Bit 13 Not assigned Bit 14 Not assigned Bit 15 Not assigned	

3.3 System error messages

3.3.1 General error messages



Note!

If the system error is retrieved via the system bus (CAN), the error messages are displayed as numbers (see column "Error message – No." of the below table).

Fault message		Description	Cause	Remedy
No.	Display			
---	---	No fault	-	-
0011	OC1	Short circuit of motor cable	Short circuit	<ul style="list-style-type: none"> Search for cause of short circuit. Check motor cable.
			Excessive capacitive charging current in the motor cable.	Use motor cable which is shorter or of lower capacitance.
0012	OC2	Motor cable earth fault	One of the motor phases has earth contact.	<ul style="list-style-type: none"> Search for cause of short circuit. Check motor cable.
0015	OC5	l x t overload	<ul style="list-style-type: none"> Frequent and too long acceleration with overcurrent Continuous overload with $I_{motor} > 1.05 \times I_{rx}$. 	Check drive dimensioning.

3 Troubleshooting and fault elimination

System error messages

General error messages

Fault message		Description	Cause	Remedy
No.	Display			
1020	OU	Overvoltage in DC bus	Braking energy is too high. (DC-bus voltage is higher than set in C0173.)	<ul style="list-style-type: none"> Use braking unit or regenerative module. Check dimensioning of the brake resistance.
1030	LU	Undervoltage in the DC bus	DC bus voltage is lower than specified in C0173.	<ul style="list-style-type: none"> Check mains voltage Check supply cable
x032	LP1	Motor phase failure	A current-carrying motor phase has failed.	<ul style="list-style-type: none"> Check motor. Check motor cable. Switch off monitoring (C0597 = 3).
			The current limit value is set too low.	<ul style="list-style-type: none"> Set higher current limit value via C0599.
0050	OH	Heatsink temperature > +90 °C	Ambient temperature $T_u > +40\text{ °C}$ or $> +50\text{ °C}$	<ul style="list-style-type: none"> Allow module to cool and ensure better ventilation. Check ambient temperature in the control cabinet.
			Heatsink is very dirty.	Clean heatsink.
			Wrong mounting position	Change mounting position.
x053	OH3	Motor temperature > +150 °C threshold (temperature detection via resolver or incremental value encoder)	Motor is thermally overloaded due to: <ul style="list-style-type: none"> Impermissible continuous current Frequent or too long acceleration processes 	<ul style="list-style-type: none"> Check drive dimensioning. Switch off monitoring (C0583 = 3).
			No PTC/temperature contact connected.	Correct wiring.
x054	OH4	Heatsink temperature > C0122	Ambient temperature $T_u > +40\text{ °C}$ or $> +50\text{ °C}$	<ul style="list-style-type: none"> Allow module to cool and ensure better ventilation. Check ambient temperature in the control cabinet. Switch off monitoring (C0582 = 3).
			Heatsink is very dirty.	Clean heatsink
			Wrong mounting position	Change mounting position.
			The value specified under C0122 is set too low.	Enter a higher value under C0122.
x057	OH7	Motor temperature > C0121 (temperature detection via resolver or incremental value encoder)	Motor is thermally overloaded due to: <ul style="list-style-type: none"> Impermissible continuous current Frequent or too long acceleration processes 	<ul style="list-style-type: none"> Check drive dimensioning. Switch off monitoring (C0584 = 3).
			No PTC/temperature contact connected.	Correct wiring.
			The value specified under C0121 is set too low.	Enter a higher value in C0121.
x058	OH8	Motor temperature via inputs T1 and T2 is too high.	Motor is thermally overloaded due to: <ul style="list-style-type: none"> Impermissible continuous current Frequent or too long acceleration processes 	<ul style="list-style-type: none"> Check drive dimensioning. Switch off monitoring (C0585 = 3).
			Terminals T1 and T2 are not connected	Connect PTC/temperature contact.
x061	CEO	Automation interface (AIF) communication error	Faulty transfer of control commands via AIF.	<ul style="list-style-type: none"> Plug in the communication module/keypad XT firmly, screw down, if necessary. Switch off monitoring (C0126 = 3).

Fault message		Description	Cause	Remedy
No.	Display			
x062	CE1	Communication error on the process data input object CAN1_IN	CAN1_IN object receives faulty data or communication is interrupted.	<ul style="list-style-type: none"> • Check wiring at X4. • Check sender. • Increase monitoring time under C0357/1, if necessary. • Switch off monitoring (C0591 = 3).
x063	CE2	Communication error on the process data input object CAN2_IN	CAN2_IN object receives faulty data or communication is interrupted.	<ul style="list-style-type: none"> • Check wiring at X4. • Check sender. • Increase monitoring time under C0357/2, if necessary. • Switch off monitoring (C0592 = 3).
x064	CE3	Communication error on the process data input object CAN3_IN	CAN3_IN object receives faulty data or communication is interrupted.	<ul style="list-style-type: none"> • Check wiring at X4. • Check sender. • Increase monitoring time under C0357/3, if necessary. • Switch off monitoring (C0593 = 3).
x065	CE4	BUS-OFF state of system bus (CAN)	The controller has received too many faulty telegrams via the system bus (CAN) and has disconnected from the bus.	<ul style="list-style-type: none"> • Check wiring at X4: Is the bus correctly terminated? • Check shield connection of the cables. • Check PE connection. • Check bus load, reduce the baud rate if necessary. (Observe the cable length!) • Switch off the monitoring (C0595 = 3).
0071	CCr	System failure	Strong interference injection on the control cables	Screen control cables
			Ground or earth loops in the wiring	<ul style="list-style-type: none"> • Check wiring • Check PE connection <p>After troubleshooting: Deenergise the device completely (disconnect 24 V supply, discharge DC bus)!</p>
0072	PR1	Checksum error in parameter set 1 CAUTION: The Lenze setting is loaded automatically!	<ul style="list-style-type: none"> • Fault when loading a parameter set. • Interruption while transmitting the parameter set via keypad. 	<ul style="list-style-type: none"> • Set the required parameters and store them under C0003 = 1. • As to PLC devices, check the use of pointers.
			The stored parameters are incompatible with the loaded software version.	Store the parameter set under C0003 = 1 first to allow for a faults reset.
0074	PEr	Program error	Error in the program flow	Send the parameter set (on floppy disk/CD-ROM) with a detailed description of the problem to Lenze. After troubleshooting: Deenergise the device completely (disconnect 24 V supply, discharge DC bus)!
0075	PR0	Error in parameter set.	The operating system software has been updated.	Storage of the Lenze setting C0003 = 1. After troubleshooting: Deenergise the device completely (disconnect 24 V supply, discharge DC bus)!

LenzePartsOnline.com

3 Troubleshooting and fault elimination

System error messages
General error messages

Fault message		Description	Cause	Remedy
No.	Display			
0079	PI	Fault during parameter initialisation	<ul style="list-style-type: none"> An error has been detected during the parameter set transfer between two devices. The parameter set does not match the controller, e.g. if data has been transferred from a higher-power controller to a lower-power controller. 	<ul style="list-style-type: none"> Correct parameter set. Send parameter set (on floppy disk/CD-ROM) and a detailed description of the problem to Lenze.
x082	Sd2	Resolver error at X7	Resolver cable interrupted.	<ul style="list-style-type: none"> Check cable for open circuit. Check resolver. Switch off the monitoring (C0586 = 3).
x083	Sd3	Encoder error at X9	Cable interrupted. Pin X9/8 not connected.	Check cable for open circuit. Apply 5 V to pin X9/8 or switch off monitoring (C0587 = 3).
x085	Sd5	Encoder error at X6/1 and X6/2 (C0034 = 1)	Current signal at X6/1 X6/2 < 2mA.	<ul style="list-style-type: none"> Check cable for open circuit. Check current signal encoder. Switch off monitoring (C0598 = 3).
x086	Sd6	Motor temperature sensor error (X7 or X8)	Encoder for detecting the motor temperature at X7 or X8 indicates undefined values.	<ul style="list-style-type: none"> Check cable for firm connection. Switch off the monitoring (C0594 = 3).
x087	sd7	Initialisation error of absolute value encoder at X8	<ul style="list-style-type: none"> Defect of the encoder electronics Absolute value encoder at X8 does not send any data. <p>Tip: The encoder may not rotate during mains switching.</p>	<ul style="list-style-type: none"> Check cable at X8 with regard to tight fit and open circuit. Check absolute value encoder with regard to correct function. Set voltage supply to 8.1 V via C0421. No Stegmann encoder connected. Replace defective encoder.
		Communication error of absolute value encoder at X8 during rotor position adjustment	A rotor position adjustment via C0095 = 1 could not be completed successfully.	Repeat rotor position adjustment. Note: After an Sd7 fault it is absolutely required to carry out a further rotor position adjustment. Otherwise the drive may carry out uncontrolled movements after controller enable. The drive may not be commissioned without having carried out a rotor position adjustment successfully! After fault correction: completely deenergise the device (switch off 24 V supply, discharge DC bus)!

LenzePartsOnline.com

Fault message		Description	Cause	Remedy
No.	Display			
x088	SD8	SinCos encoder at X8 sends inconsistent data.	The tracks in the SinCos encoder are damaged.	Replace SinCos encoder.
			Interference level on the encoder cable is too high.	<ul style="list-style-type: none"> Check correct shield connection of encoder cable. Where required, decelerate the actuation of the fault message via the filter time constant. Setting: <ul style="list-style-type: none"> – for ECSxS/P/M/A in C0559. – for 9300 servo cam in C0575.
		SinCos encoder at X8 does not send any data.	Open circuit.	Check cable with regard to open circuit.
			Incorrect encoder connected.	Connect SinCos encoder of the company Stegmann.
			SinCos encoder defective.	Replace SinCos encoder.
	Supply voltage set incorrectly.	Set voltage supply in C0421.		
				After fault correction: completely deenergise the device (switch off 24 V supply, discharge DC bus)!
x089	PL	Fault during rotor position adjustment (the fault is stored safe from mains failure)	<ul style="list-style-type: none"> The rotor position adjustment has been aborted. During rotor position adjustment with absolute value encoder the fault Sd7 or SD8 has occurred. 	Restart rotor position adjustment with C0095 = 1. Then reset TRIP.
x091	EEr	External monitoring has been triggered via DCTRL.	A digital signal assigned to the TRIP-SET function has been activated.	<ul style="list-style-type: none"> Check external encoder. Switch off the monitoring (C0581 = 3).
0105	H05	Internal fault (memory)		Contact Lenze.
0107	H07	Internal fault (power stage)	During initialisation of the controller, an incorrect power stage was detected.	Contact Lenze.
x110	H10	Heatsink temperature sensor error	Sensor for detecting the heatsink temperature indicates undefined values.	<ul style="list-style-type: none"> Contact Lenze. Switch off the monitoring (C0588 = 3).
x111	H11	Temperature sensor error: Temperature inside the controller	Sensor for detecting the internal temperature indicates undefined values.	<ul style="list-style-type: none"> Contact Lenze. Switch off the monitoring (C0588 = 3).
x151	P01	Error "negative limit switch".	Negative limit switch was reached.	<ul style="list-style-type: none"> Control drive in positive direction Check wiring at X5/E2.
x152	P02	Error "positive limit switch".	Positive limit switch was reached.	<ul style="list-style-type: none"> Control drive in negative direction Check wiring at X5/E1.
x153	P03	Following error	The angle difference between set and actual position is larger than the following error limit set under C0255.	<ul style="list-style-type: none"> Increase following error limit under C0255. Switch off the monitoring (C0589 = 3).
			Drive cannot follow the digital frequency (I_{max} limit).	Check drive dimensioning.
x154	P04	Error "negative position limit".	Negative position limit (C1224) was not reached.	Find out why the value was not reached (e.g. "incorrect" position targets, set function position value) and adjust the position limit in C1224 if necessary.
x155	P05	Error "positive position limit".	Positive position limit (C1223) was exceeded.	Find out why the value was exceeded (e.g. "incorrect" position targets, set function position value) and adjust the position limit in C1223 if necessary.

3 Troubleshooting and fault elimination

System error messages

General error messages

Fault message		Description	Cause	Remedy
No.	Display			
x156	P06	No reference.	The reference point is not known. In the case of absolute positioning, no homing was performed before the first positioning.	Perform one of the following functions and restart: <ul style="list-style-type: none"> • Manual homing. • Start homing in the program. • Set reference.
x157	P07	Parameter set mode is absolute instead of relative.	An absolute parameter set (C1311) was performed during relative positioning (position mode C1210).	Perform one of the following functions and restart: <ul style="list-style-type: none"> • Change the parameter set from absolute to relative. • Change position mode.
x158	P08	Error "actual reference dimension offset".	Actual reference dimension offset (C1226) outside the position limits. Error of the program function "set position value".	If necessary, adapt the position limit values or check whether the program function "set position value" is to be applied.
x159	P09	Error in positioning program.	Impermissible programming	Check position program: <ul style="list-style-type: none"> • A parameter set with final speed must be followed by a parameter set with positioning; it is not permissible to wait for input.
x162	P12	Error in the range of the encoder.	The range of the absolute encoder was exceeded.	<ul style="list-style-type: none"> • Return drive by manual positioning. • Check position limits and adjustment of the encoder. • Design and mount the absolute encoder in a way that does not exceed the traversing range.
x163	P13	Angle overrun.	<ul style="list-style-type: none"> • Phase controller limit reached • Drive cannot follow the digital frequency (I_{max} limit). 	<ul style="list-style-type: none"> • Enable drive • Check drive dimensioning.
x164	P14	1. Following error.	The drive cannot follow the setpoint. The following error is greater than the limit value in C1218/1.	<ul style="list-style-type: none"> • Increase current limit under C0022 (observe max. motor current). • Reduce acceleration. • Check drive dimensioning. • Increase limit value under C1218/1
x165	P15	2. Following error.	The drive cannot follow the setpoint. The following error is greater than the limit value in C1218/2.	<ul style="list-style-type: none"> • Increase current limit C0022 (observe max. motor current). • Reduce acceleration. • Check drive dimensioning. • Increase limit value under C1218/2

LenzePartsOnline.com

Fault message		Description	Cause	Remedy
No.	Display			
x166	P16	Faulty transfer of system bus (CAN) sync telegram.	The sync telegram from the master (PLC) is out of sync cycle.	<ul style="list-style-type: none"> Set the "sync cycle" to the transmission cycle of the master (PLC) under C1121. Note: <ul style="list-style-type: none"> C0362 displays the time interval between 2 sync telegrams. C0362 = 0: communication interrupted.
			The sync telegram of the master (PLC) is not received.	<ul style="list-style-type: none"> Check communication channel. Check baud rate, controller address. Note: <ul style="list-style-type: none"> C0362 displays the time interval between 2 sync telegrams. C0362 = 0: communication interrupted.
			The controller is enabled too fast.	<ul style="list-style-type: none"> Delay the controller enable. The time delay required depends on the time interval between the sync telegrams.
x167	P17	Error "touch probe control".	Various function blocks use the touch probe input at the same time (e.g. FB DFSET and POS). A conflict arises.	<ul style="list-style-type: none"> Configure another touch probe input for FB POS (not possible for FB DFSET). Switch off monitoring (C1289/1).
x168	P18	Internal limitation.	Arithmetic operation generated data cannot be varied arbitrarily. Wrongly specified values were automatically limited internally.	
			C1298 = 1: The negative position limit in C1223 is outside the possible display range of $1 \leq (C1223 \times C1205) \leq 1.07E9 \text{ inc}$	Check the values in C1202/4, C1207/1, C1207/2. Read out the limited value in C1220/10 and enter it in C1223 if necessary.
			C1298 = 2: The positive position limit in C1224 is outside the possible display range of $1 \leq (C1224 \times C1205) \leq 1.07E9 \text{ inc}$	Check the values in C1202/4, C1207/1, C1207/2. Read out the limited value in C1220/11 and enter it in C1224 if necessary.
			C1298 = 3: The maximum speed v_{\max} in C1240 is outside the possible display range of $1 \leq (C1240 \times C1205 \times 16.384) \leq 2.14E9 \text{ inc}$ or $v_{\max} \text{ not } C1240 / C1204 \times 60 \leq 1.5 \times n_{\max}$	Check the values in C0011, C1202/4, C1207/1, C1207/2. Read out the limited value in C1220/12 and enter it in C1240 or adjust the value in C1240 to C0011 if necessary.
			C1298 = 4: The maximum acceleration a_{\max} in C1250 is outside the possible display range of $1 \leq (C1250 \times C1205 \times 16.384 / 1000) \leq 2.8634E7 \text{ inc}$	Check the values in C1202/4, C1207/1, C1207/2. Read out the limited value in C1220/13 and enter it in C1250 if necessary.
C1298 = 5: An internal value range has been exceeded for a speed standardisation. Valid range: $1 \leq (C0011 \times C1207/1 / C1207/2 \times 65536 / 60000) \leq 32767$	Check the values in C0011, C1207/1, C1207/2 and correct them.			

3 Troubleshooting and fault elimination

System error messages

General error messages

Fault message		Description	Cause	Remedy
No.	Display			
x169	P19	The input values at X9 are limited.	The function block DFIN limits the input values. This causes the loss of increments.	<ul style="list-style-type: none"> ● Reduce the frequency on the digital frequency connection. ● Check the settings for the slave (C0425) and for the master (C0030). These settings must be identical.
x171	P21	Following error.	The phase difference between set and actual position is larger than the following error limit set under C1328.	<ul style="list-style-type: none"> ● Extend the following error limit under C1328. ● Switch off monitoring (C1329=3).
			Drive cannot follow the digital frequency (I_{max} limit).	Check drive dimensioning.
x190	nErr	Speed control error (Speed out of tolerance margin (C0576))	<ul style="list-style-type: none"> ● Active load (e.g. for hoists) is too high. ● Mechanical blockades on the load side 	Check drive dimensioning.
x200	Nmax	Maximum speed (C0596) has been exceeded.	<ul style="list-style-type: none"> ● Active load (e.g. for hoists) is too high ● Drive is not speed-controlled, torque is excessively limited. 	<ul style="list-style-type: none"> ● Check drive dimensioning. ● Possibly increase torque limit. ● Switch off monitoring (C0607 = 3).
x220	CDA	Data error	Attempt to transmit faulty profile data	Repeat profile data transfer.
x221	CDA-LOAD	Faulty checksum	The checksum of the transferred profile data is not correct.	Repeat profile data transfer and check for correctness.



Explanation of the error numbers:

x 0 = TRIP, 1 = message, 2 = warning, 3 = FAIL-QSP

e.g. "2091": An external monitoring has triggered the warning EEr



3.3.2 Resetting system error messages

Reaction	Measures to reset the fault message
TRIP/ FAIL-QSP	 <p>Note! If a TRIP/FAIL QSP source is still active, the pending TRIP/FAIL QSP cannot be reset.</p> <p>The TRIP/FAIL QSP can be reset by:</p> <ul style="list-style-type: none"> • pressing ⇒ STOP on keypad XT EMZ9371 BC. Then, press RUN to re-enable the controller. • Set code C0043 = 0. • Control word C0135, bit 11 • Control word AIF • Control word system bus (CAN) / MotionBus (CAN) at ECSxS/P/M <p>After the reset of the TRIP/FAIL QSP, the drive remains at standstill.</p>
Message	 <p>Danger! The fault message is reset automatically after the fault has been eliminated, and the drive restarts automatically.</p>
Warning	After the fault has been eliminated, the fault message is reset automatically.

LenzePartsOnline.com

Lenze Drive Systems GmbH
Hans-Lenze-Straße 1
D-31855 Aerzen
Germany



Service



Service

E-Mail

Internet

+49 (0) 51 54 82-0

00 80 00 24 4 68 77 (24 h helpline)

+49 (0) 51 54 82-1112

Lenze@Lenze.de

www.Lenze.com



EDKVS93-03
DE 1.0
© 06/2008
TD23

LenzePartsOnline.com